



VP60 Injection Molded Lens

VP60

7-1/8" x 49-15/16" x 2-1/2"
181mm x 1268,41mm x 63,5mm

Injection Molded for enclosed and gasketed fixtures. Available with or without gaskets.

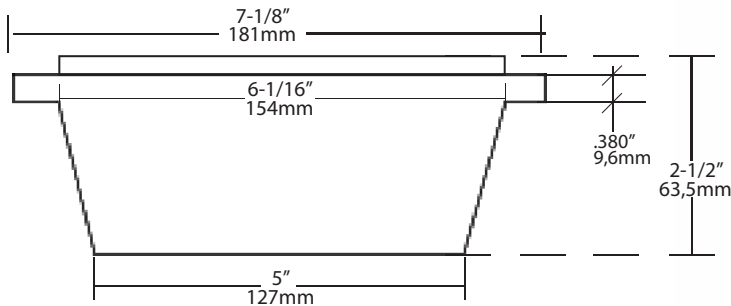

VP60 INJECTION MOLDED LENS

POLYCARBONATE				
FINISH	DIMENSIONAL SIZE	PART #	PCS/CTN	CTN. WT.
WITHOUT GASKETS				
<u>CLEAR FROSTED</u>	7-1/8" X 49-15/16" X 2-1/2"	VP-60-PC-749	10	39LBS/17.7KG
<u>WHITE</u>	7-1/8" X 49-15/16" X 2-1/2"	VP-60-PCW-749	10	39LBS/17.7KG
WITH GASKETS				
<u>CLEAR FROSTED</u>	7-1/8" X 49-15/16" X 2-1/2"	VP-60-PC-749-WG	10	39LBS/17.7KG
<u>WHITE</u>	7-1/8" X 49-15/16" X 2-1/2"	VP-60-PCW-749-WG	10	39LBS/17.7KG

Product offering and specifications subject to change without notice.

SLP LIGHTING

PHONE: 636.600.4084 | 800.248.0224 FAX: 636.600.4108

www.slplighting.com V020112